

User Manual

SKL5010 – Contactless USB2.0

1. Overview

This document guides users how to use the SKL5010A/B modules. The pair of modules transmits USB2.0 signals or UART/GPIO/I2C at a distance of several centimeters in a contactless way. SKL5010 opens a new scene for USB2.0 connection applications. This module integrates a MCU and ST60A3, a millimeter wave wireless transceiver chip, which can be simply connected to the existing USB Type-c interface replacing a USB2.0 cable.

2. Block diagram

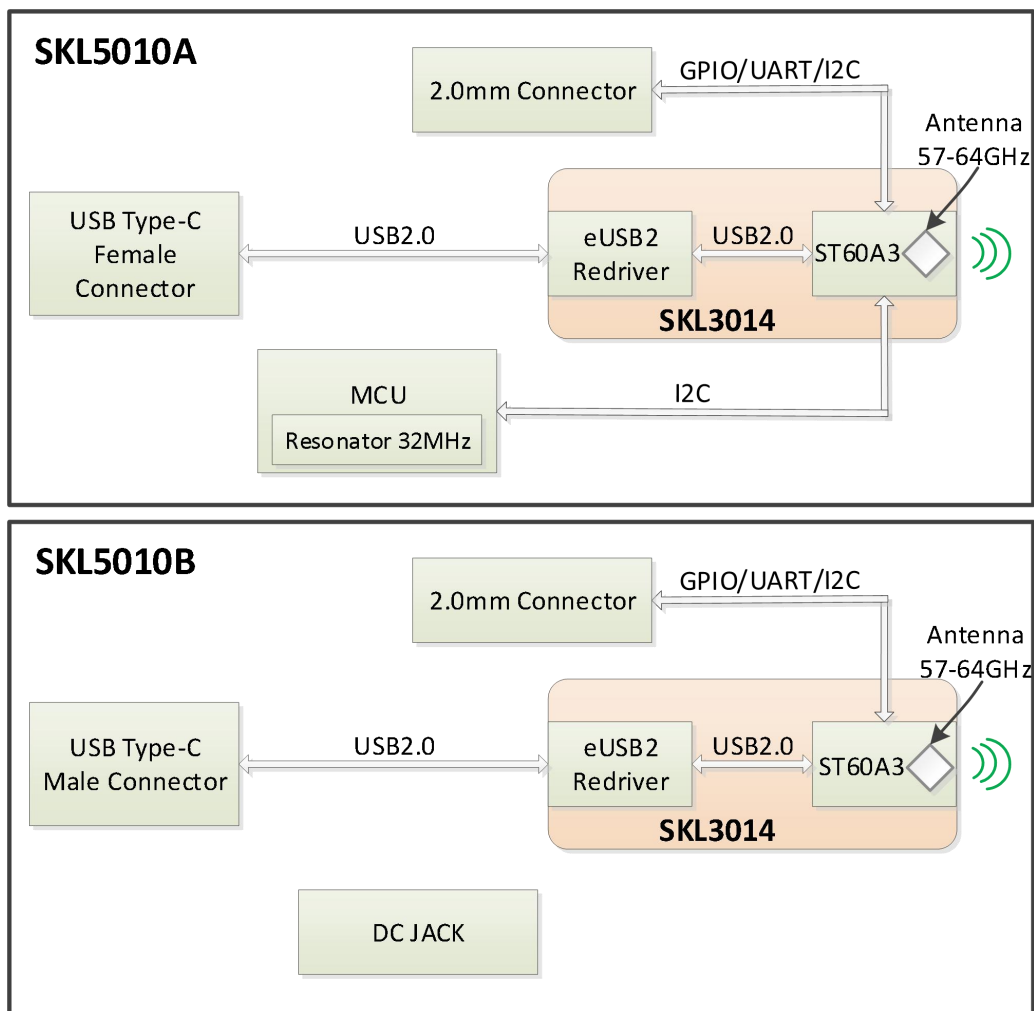

Figure 1. Schematic diagram of SKL5010

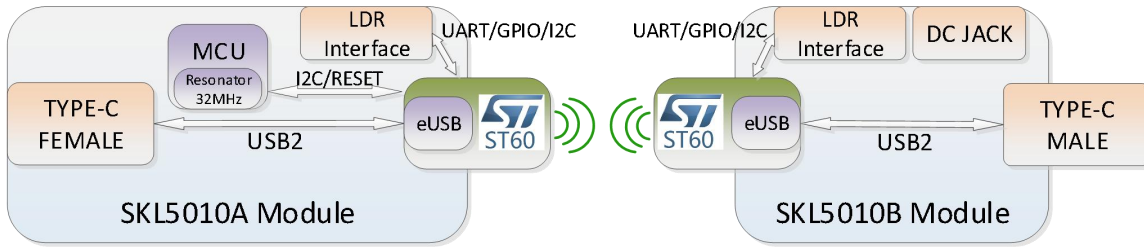

Figure 2. Schematic diagram of SKL5010

Board outlook:

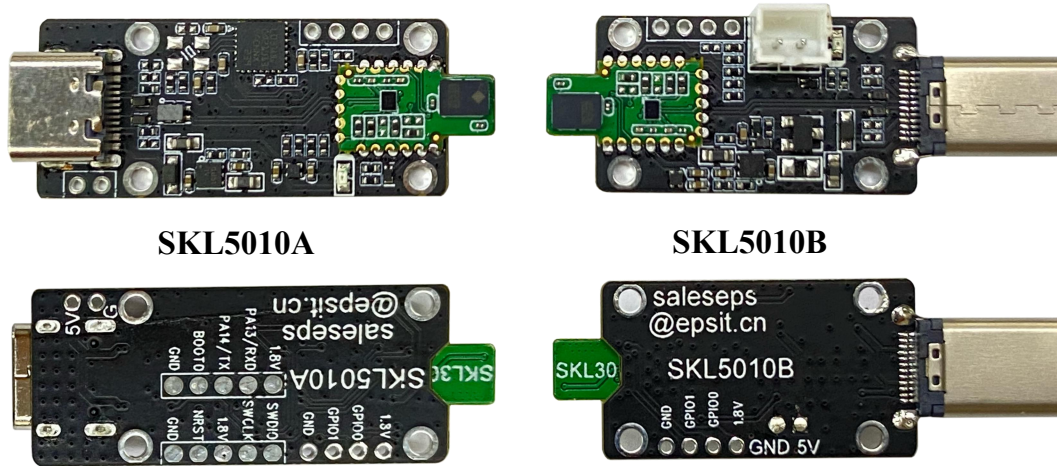

Figure 3. Board outlook of SKL5010

3. Connection method

ST60A3 is ST60 GHz V-Band transceiver for contactless connectivity up to 480Mbps, SKL5010 is the Modules integrate ST60A3 and support USB2.0/UART/GPIO/I2C interface.

Mode selection:

The SKL5010A can change the level of the MCU's PB0 by switching the position of the resistor to select the SKL5010's operating mode. PB0 defaults to high level, meaning SKL5010 operates in USB2.0 tunneling mode. When PB is low, SKL5010 will work in one of the UART/GPIO/I2C tunneling modes, the UART, GPIO and I2C tunneling modes are determined by the program burned into the MCU.

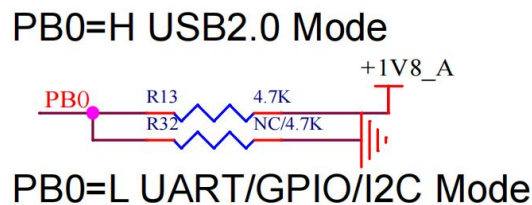

Figure 4. Mode selection 1

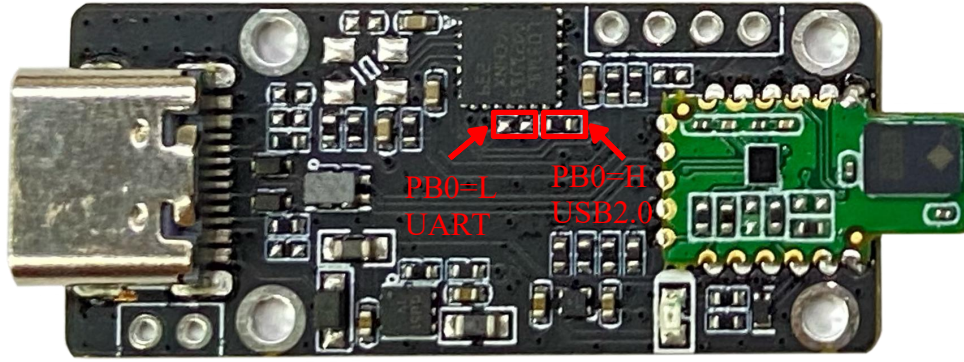

Figure 5. Mode selection 2

USB2.0 Tunneling Mode Connection diagram:

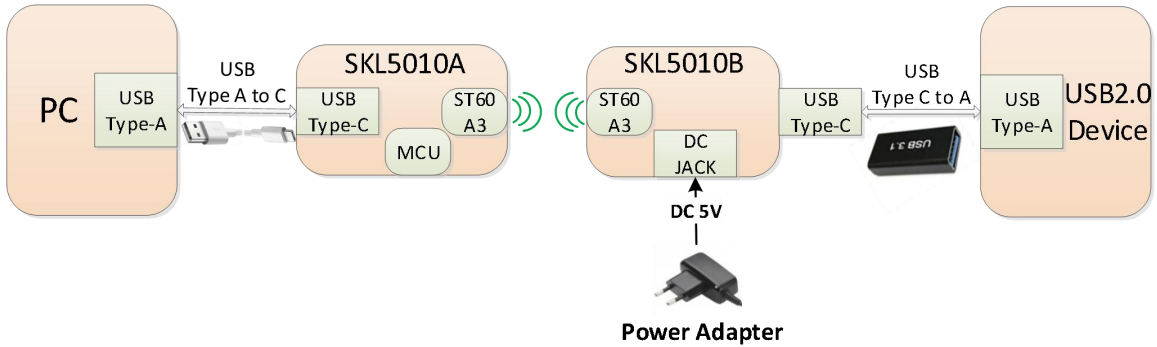

Figure 6. Schematic diagram of using SKL5010 to connect USB2.0 Device

SKL5010A is in host mode, and the input interface is USB Type-C female, which can be connected to PC through USB Type A to C data cable, and directly powered by PC through USB cable. SKL5010B is in device mode, and the output interface is USB type-C male. It needs external 5V power supply and can be connected to any USB2.0 devices, such as USB disk, USB camera, etc.

Installation Method:

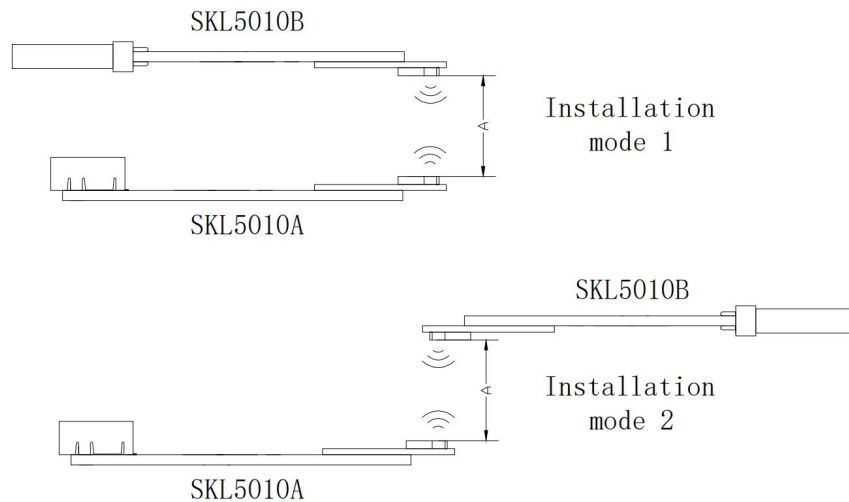

Figure 7. Connection mode of SKL5010A and SKL5010B

Please note that SKL5010A and SKL5010B must be used in pairs, and the Integrated antenna part needs to be aligned face to face with a distance ('A') of less than 6cm, preferred 3cm. Both 0° and 180° relative orientations are supported as shown in figure.

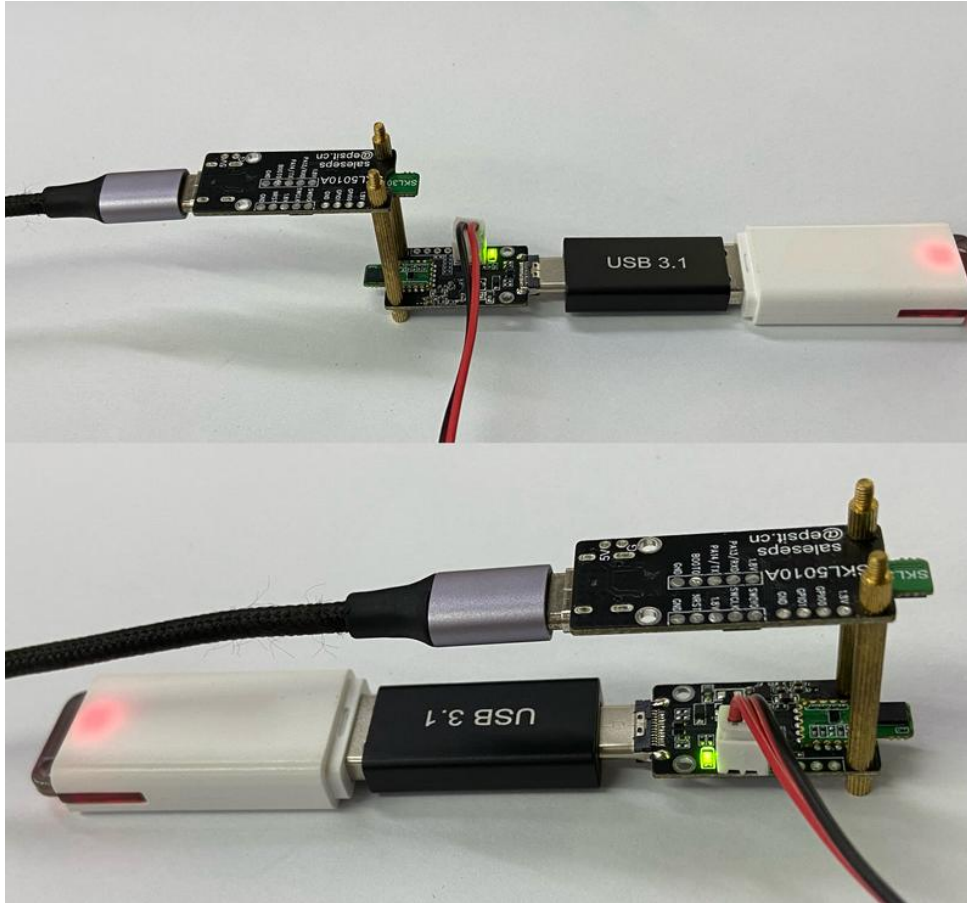

Figure 8. Physical picture of SKL5010 non-contact connector

LED Indicator:

Both SKL5010A and SKL5010B have a green LED indicator to indicate the three states of SKL5010.

1. When the green LED lights up but the brightness is low, it indicates that the power supply of SKL5010 is normal, but the wireless connection is not established.

2. When the green LED brightness becomes high and blinks, it indicates that SKL5010A and SKL5010B are establishing a communication connection.

3. When the green LED brightness becomes high and is always on, it indicates that SKL5010A and SKL5010B have established communication and can work normally.

Note that the SKL5010B will not start powering the USB device until after the Link is established.

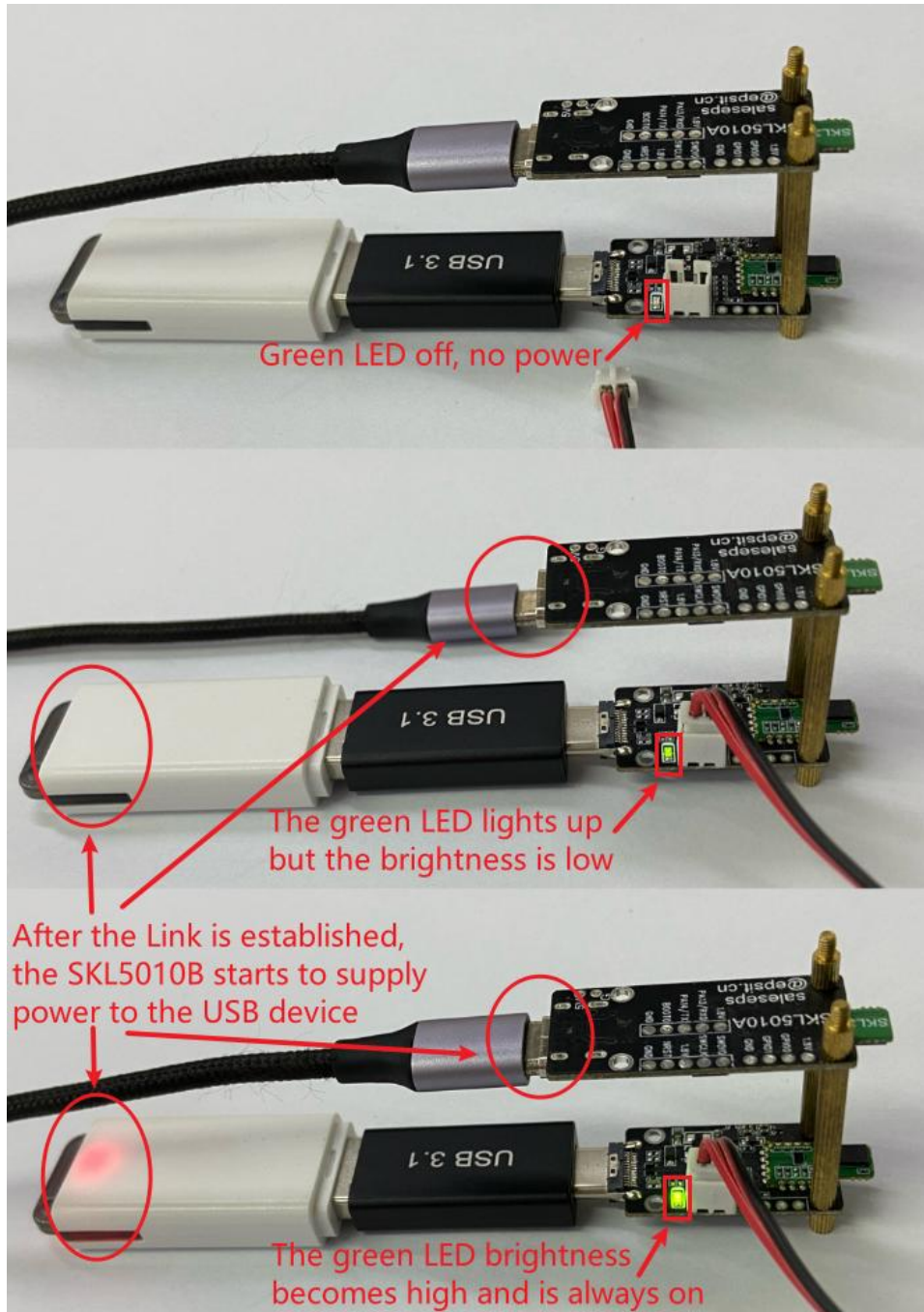

Figure 9. LED indicator status mode

Connect to Smart Phone:

As shown in the following figure, SKL5010 can also transfer data from a smartphone with a type-c interface to a PC.



Figure 10. SKL5010 connect to Smart Phone

UART Tunneling Mode Connection:

Soldering the pull-down resistor of PB0 will make PB0 of SKL5010A low and put the module in UART tunneling mode. The contactless UART data communication can be tested by powering the module through the 2.0mm pin header, as well as connecting the USB to UART tool and then connecting it to a PC.

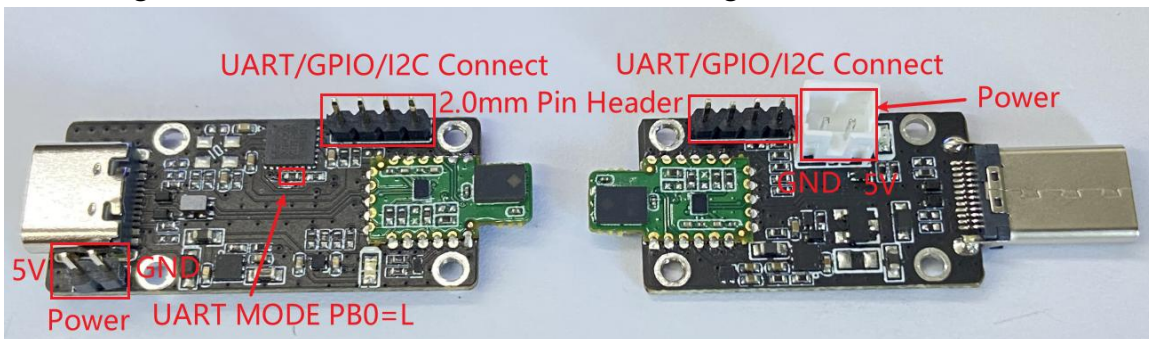

Figure 11. Setting the SKL5010 to UART Tunneling Mode



Figure 12. UART Tunneling

The SKL5010 module can transmit UART signals via the GPIO0(RX) and GPIO1(TX) pins.

Pin Number	Signal Name	Description
1	1V8	Power supply, 1.8V
2	GPIO0	UART(RX)/I2C(SCL)/GPIO tunneling, 1.8V level
3	GPIO1	UART(TX)/I2C(SDA)/GPIO tunneling 1.8V level
4	GND	Ground

The following is the test block diagram of the SKL5010 module in UART tunnel mode:

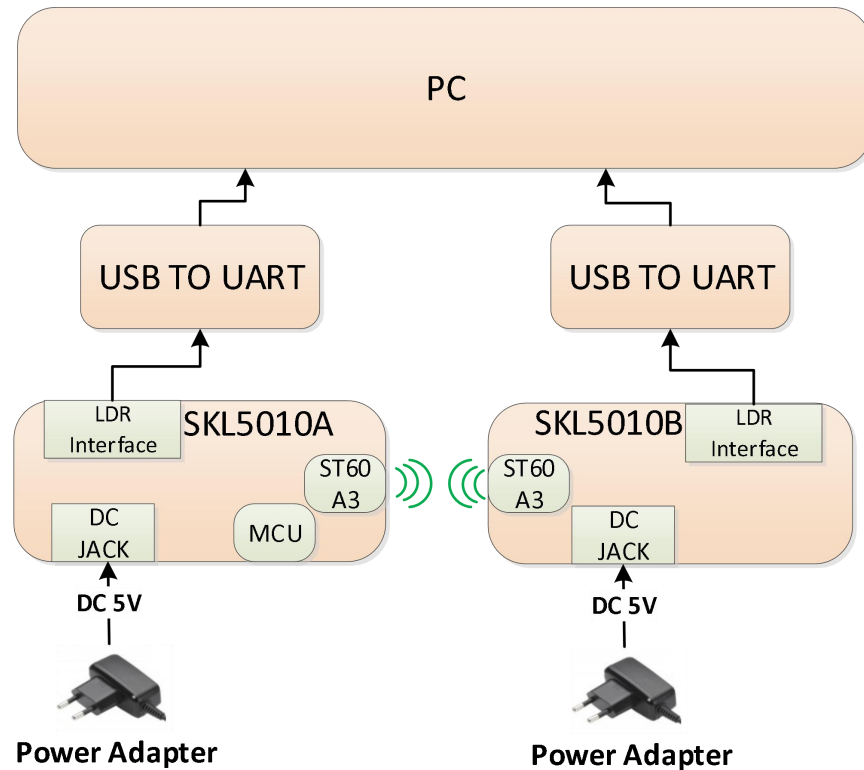

Figure 13. Connection block diagram for testing UART communication using SKL5010

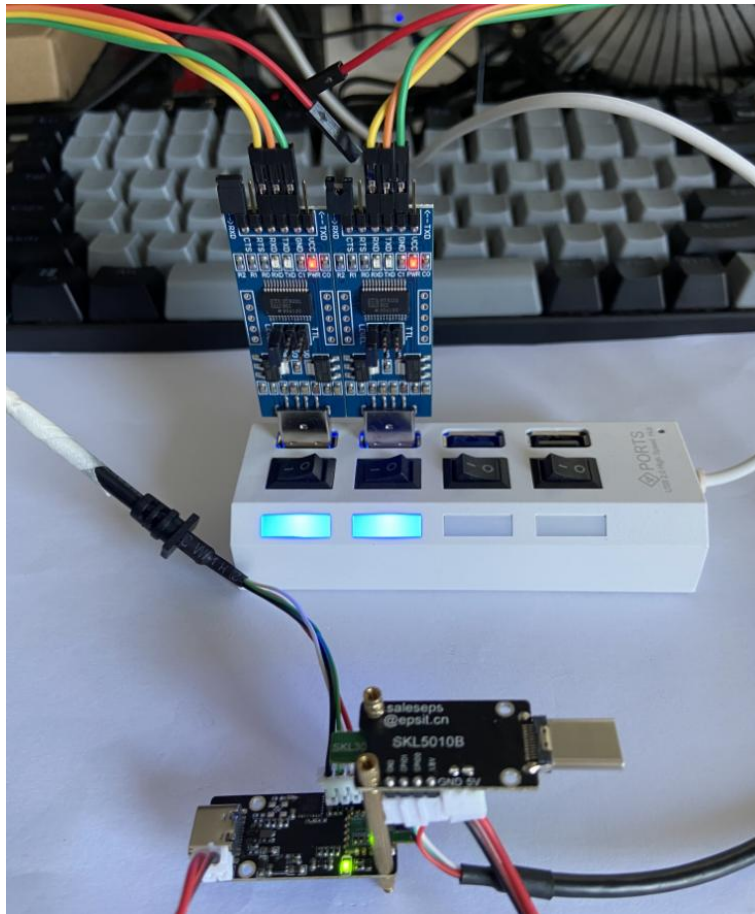

Figure 14. Connection block diagram for testing UART communication using SKL5010

The above figure shows the physical diagram of the UART tunnel mode connection of the SKL5010 module.

Note that both GPIO0 and GPIO1 are at 1.8V levels, so the USB to UART tool needs to be able to match 1.8V levels as well.

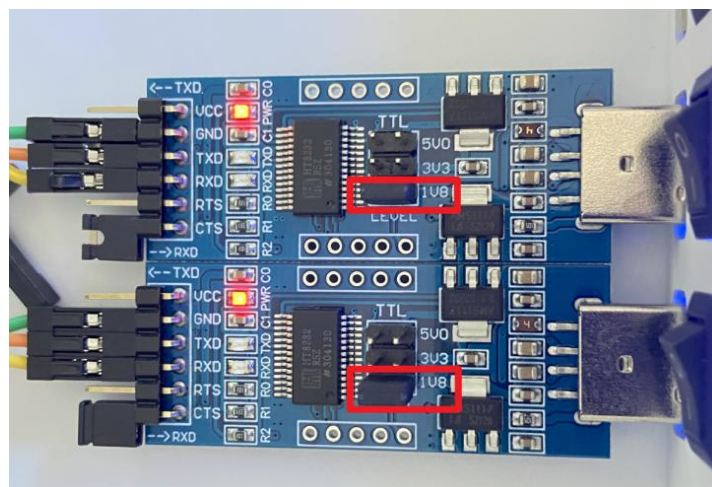

Figure 15. USB to UART Tool

The computer is tested for UART communication through the serial port debugging tool.



Figure 16. PC's UART Debugging Tools

GPIO Tunneling Mode Connection:

Please refer to UART Tunneling Mode for GPIO Tunneling Mode setting method and connection.

GPIO Tunneling Mode requires specific firmware to be burned, please contact the EPS FAE if needed.

I2C Tunneling Mode Connection:

Please refer to UART Tunneling Mode for I2C Tunneling Mode setting method and connection.

I2C Tunneling Mode requires specific firmware to be burned, please contact the EPS FAE if needed.

4. Environment constraints

PCB installation:

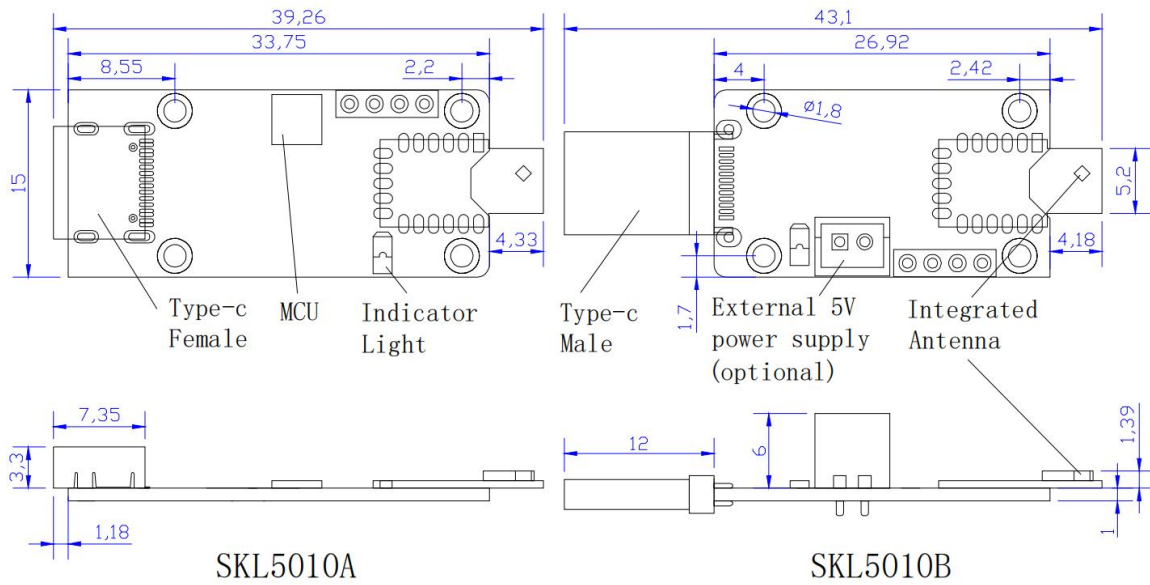

NOTE: If a metal cover is used, a window should be added for microwave signal. Plastic or other microwave insensitive materials can be used to fill the window.

5. Characteristics

Recommended operating conditions and electrical characteristics

Symbol	Description	Min	TYP	Max	Unit
V_{IN}	Power supply	4.5	5	5.5	V
C_{IN}	Input current(*)	-	42	-	mA
P	Total Power consumption	-	0.21	-	W
T_A	Ambient Operating Temperature, for SKL5010A/B	-20	-	85	°C
F_{osc}	Carrier Frequency	60.3	60.4	60.5	GHz

FCC Statement:

This device complies with Part 15 of the FCC Rules. Operation is subject to the following two conditions:

- (1) This device may not cause harmful interference, and
- (2) this device must accept any interference received, including interference that may cause undesired operation.

This equipment has been tested and found to comply with the limits for a Class B digital device, pursuant to Part 15 of the FCC Rules. These limits are designed to provide reasonable protection against harmful interference in a residential installation. This equipment generates, uses and can radiate radio frequency energy and, if not installed and used in accordance with the instructions, may cause harmful interference to radio communications. However, there is no guarantee that interference will not occur in a particular installation. If this equipment does cause harmful interference to radio or television reception, which can be determined by turning the equipment off and on, the user is encouraged to try to correct the interference by one of the following measures:

- Reorient or relocate the receiving antenna.
- - Increase the separation between the equipment and receiver.
- Connect the equipment into an outlet on a circuit different from that to which the receiver is connected.
- - Consult the dealer or an experienced radio/TV technician for help.

FCC Caution: Any changes or modifications not expressly approved by the party responsible for compliance could void the user's authority to operate this equipment. This transmitter must not be co-located or operating in conjunction with any other antenna or transmitter.

Revision History

Date	Version	Changes
Dec 8 2023	1.4	Updated Block diagram
Oct 25 2023	1.3	Add FCC parts, Update 'Schematic diagram of SKL5010'
Sep 25 2023	1.2	Updated model name SKL5010, Update all features
APR 25 2022	1.1	Update 'Connect to Smart Phone'
APR 25 2022	1.0	Update power supply
APR 05 2022	0.9	Initial Release